

TECHNICAL DESCRIPTION

L3-4020 LASER SYSTEM

L3-4020 - L3 system

Fiber laser system for cutting sheet metal blanks in two dimensions. Salvagnini adopts an original and compact design for the structure and the resulting field of action of the axes. This combines high performance, easy access typical of cantilever structures with the stability of gantry structures.



The machine is equipped with:

- active fiber that carries the laser beam from the source to the focusing head;
- proprietary focusing head made to enhance the characteristics and dynamics offered by optical fiber transmission.

The head is made for a 200mm single auto-focusing lens and is equipped with a collimator for the beam exiting the delivery fiber and a plug-in lens housing designed to give easy access to the focusing lens so that it can be inspected or cleaned without having to realign the laser beam. The single auto-focusing lens makes it possible to cut the entire range of permitted thicknesses and materials, guaranteeing fast production changes and eliminating the need for adjustments.

The lens is radially cooled by nitrogen acting on the whole surface of the lens hit by the laser beam, guaranteeing more uniform cooling and no thermal deformation.

Focusing head



The head is equipped with a capacitance sensor which maintains the nozzle in a position programmed with respect to the surface of the metal sheet. This sensor also acts as anti-collision system detecting any obstacles along the head path.

- circuit for supplying two different types of assist gases (Oxygen or Nitrogen); the circuit is equipped with automatic pressure regulator and fine filtering system;
- Salvagnini table changeover system composed of an internal structure integral with the machine body, and an external one with devices for both horizontal and vertical translation. The table with the cut parts is extracted from the cutting zone by passing under the table with the sheet to be cut thus excluding the possibility of scrap falling on the sheet to be cut. This type of handling increases the reliability of the process optimizing the table changeover cycle.
- plate referencing performed using the plate detection cycle which takes advantage of the capacitance sensor properties without moving the plate over the grids
- equipment and automatic cycle to quickly identify the real focal length of the lens used and to carry out the programmed and automatic cleaning of the nozzle;
- ergonomic command console.

The main operating characteristics are:

max. length of sheet that can be processed	4064 mm
max. width of sheet that can be processed	2032 mm
Z axis stroke	100 mm
max. weight of sheet	1250 kg
fast speed along X	120 m/min
fast speed along Y	100 m/min
fast speed along Z	30 m/min
max. acceleration X axis	1.5 g
max. acceleration Y axis	2.0 g
work-table height	980 mm

GF - Grids with mild steel slats

Grids with interchangeable mild steel slats for the laser's pallet changeover system.

CRS - Scrap collection bins

Scrap collection bins placed beneath the work-surface and able to collect any scrap produced during the work-cycle. The operator can easily remove the bins for cleaning.

SiX - System control and management

High performance proprietary control system distributed on 3 levels.

- Elaboration unit for managing and supervising the machine. The unit is composed of a DELL workstation with Windows 7 Professional English (32 Bit) operation system equipped with: SATA hard disk, two ETHERNET TCP/IP network cards, UTP cable with RJ45 connector and Teamviewer software for information exchange between the system and various Salvagnini depts. such as Service, Automation, Studies & Applications. To use the Teamviewer software, the http protocol must be enabled on port 80 or port 5938 of the customer's LAN network (this does not imply system access to internet).

The workstation is equipped with HW and SW *System Backup* package composed of an RHD (Removable Hard Disk) and of the management software that allows the customer to automatically backup the whole main HD into the new RHD support.

The operator is automatically and periodically reminded to carry out the backup procedure by video warnings.

The workstation, which is an integral part of the SiX control system, is tested and configured according to exact Salvagnini specification to communicate with the control unit and grant remote service. The hardware and software configurations cannot be modified by the customer.

- Control unit which communicates in real-time with the interface section through a high-performance VME bus and one or more field buses (EtherCAT and CANopen).
- Input/output interface section towards peripheral devices such as drives, solenoid valves, sensors, etc.

The UPS (Uninterruptible power supply unit) installed inside the system power cabinet allows the SiX control and the elaboration unit to be correctly shut-down in case of sudden blackouts.

FLR40 - 4000 W Fiber laser source with cooling unit

Solid state laser source in which the laser beam is generated by using fiber-coupled pump diode modules to energize the active optical fiber.

The 'fiber' technology guarantees and is characterized by:

- extremely low energy consumption, thanks to the laser source's high yield;
- low running and maintenance costs, given the absence of optical resonator, internal reflecting mirrors, turbine and other moving mechanical parts.

The laser beam is of high quality and has high power density; moreover, no optical path is needed as the beam is carried to the work area by an optical fiber.

No laser gas circuit is required.

A double-circuit double-temperature cooling unit to separately cool the fiber laser source and the focusing head, is also supplied with the source.

Functioning principle for the fiber laser source

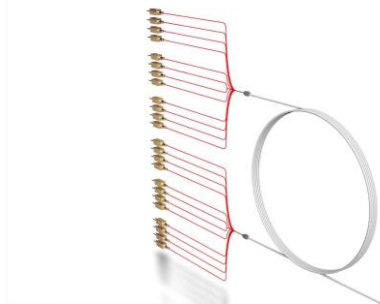

Generation and transport of laser beam in fiber

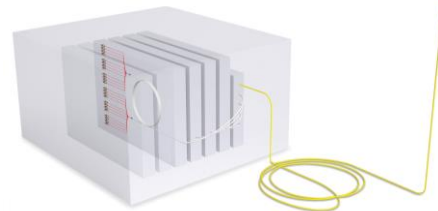

The following table summarizes the cutting limit capabilities for commonly used materials with a 4000W source. The cutting quality on the thinnest and thickest material will depend on the geometry required, the quality of the material and the operating conditions of the system; with the maximum thicknesses, there may be burring on the lower face.

Material of reference	Cutting limit
Mild steel (S185JR,S235JR, RAEX 250 C LASER)	20 mm
Stainless steel (AISI 304, X5CrNi18-10 1.4301)	15 mm
Aluminum (Al 99.5 EN AW 1050A)	15 mm
Copper (Cu-ETP CW004A H040 EN1652)	8 mm
Brass (CuZn37 CW508L H055 EN1652)	8 mm

APC - Adaptive piercing control

Option of the Salvagnini proprietary focusing head THF composed of a sensor which reads the light spectrum coming from the material being cut.

Thanks to this sensor, the control functions are able to start the cutting phase as soon as the piercing is completed, and to adjust the piercing parameters to the material answer.

The APC drastically reduces piercing time, and therefore the part total cycle time, while improving quality, process reliability and saving assist gas and energy.

ASF - Fume extraction

Option for the Salvagnini system consisting of a filtering unit to extract and filter fumes and dust generated during sheet metal laser cutting.

Its main components are:

- filtering section consisting of high efficiency filtering sleeves;
- pneumatic unit for sleeve cleaning;
- suction fan;
- spark trap;
- switchboard for functions command and control;
- dust collection bin.

The filtering unit guarantees a 99.999% filtering efficiency for particles over 0.5 μm , and less than 2 mg/m^3 of residual dust in suspension.

The supply includes piping to connect the filtering unit to the machine.

Note:

When processing aluminum alloys, the magnesium dust accumulated can generate an explosion hazard. In such cases, the ASFAD explosion-proof fume extractor or, alternatively, the NAIS neutralizing agent injection system, can be used. The ASFAD or the NAIS options are not included in this configuration; if required, the chosen solution has to be studied on the basis of the actual uses.

NAIS - Injection system for CaCO_3 neutralizing agent

Neutralizing injection system that, used with the ASF fume extractor, reduces the risk of explosion of dust generated when using a laser to continually cut aluminum alloys.

The injection system releases the neutralizing material in the suction flow from the ASF at a preset emission cycle of a few seconds every few minutes.

The neutralizing material used is calcium carbonate (CaCO_3).

The injection system is also equipped with a weighing system capable of measuring the quantity of neutralizing material released each time as well as its progressive consumption. If the quantity released during the emission cycle is less than the pre-set value, a further emission cycle is activated before stand-by. If the minimum quantity of neutralizing material is not reached in two continuous cycles, the system sends an error signal.

The parameters can be modified to synchronize the machining with the quantity and characteristics of the dust generated during cutting.

When the total quantity of neutralizing material in the injection system falls below the set minimum threshold, the system sends an error signal.

The system must be turned on manually.

Any modifications needed for the positioning of this option are not included in the supply and will be quoted separately.

The customer must clean and maintain the pipes connecting the filtering unit to the machine and the suction collector to prevent accumulation of dust generated by the constant cutting of aluminum alloys.

AVS - Artificial Vision System for referencing sheet or parts

AVS is the artificial vision application for the Salvagnini laser systems; it is the fruit of Salvagnini's consolidated experience in the application of this technology and of the attention it directs to the expansion of laser systems to new application sectors.

AVS includes an HD camera placed near the cutting head that, before the cutting cycle, rapidly and accurately detects the exact position of segments or shapes given in a dxf/dwg drawing in order to define the real reference system.

During the work cycle the AVS is protected by an automatic closing device. In case of difficult reading (use of reflecting material such as aluminum, stainless steel or special coatings) the sensor performance must be verified by Salvagnini beforehand. The sheet area within which shapes can be detected is 2980 mm in X and 1380 mm in Y.

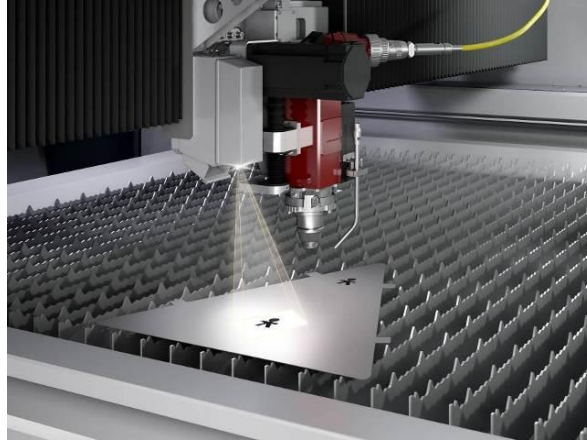

Note: the AVS must be subjected to a feasibility analysis.

ANC - Automatic nozzle change

Device developed to allow different types of material and thicknesses to be cut without operator intervention, thanks to the automatic change of nozzles.

The ANC consists of an 8-position nozzle carrier which, by moving to a predefined position, allows the nozzle being used in the head to be quickly changed with the new nozzle.

SIMFIBER - Laser cutting process simulator

The SIMFIBER simulator has been developed for those who work directly on the laser machine as well as for those who program production from the office programming station.

The application is used to exactly view the sequence of operations of a laser processing program, i.e. the parts, the tool path and the processing technologies employed. The machine movements are shown on the screen as computerized animation of the tool path and can be also shown in real time during actual machining; this animation can be slowed down or stopped to provide dimensional or technological information.

In addition to the sequence of operations, the change in speed and power parameters along the cutting path can also be viewed.

Through the SIMFIBER graphic interface, the size or number of micro-joints on the parts can be swiftly and interactively changed directly from the machine computer

SIMFIBER

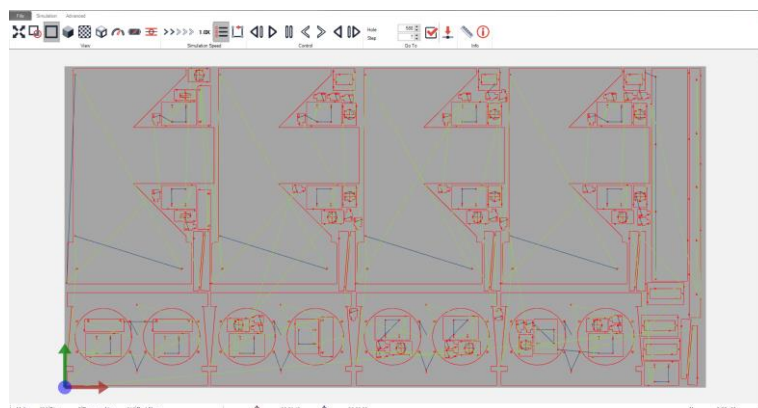

JOB.CONSOLE.L - Software for managing the production and the Laser system

JOB.CONSOLE is the set of Salvagnini software packages integrated in the SiX control system, which graphically allows the system to be easily used, managed and supervised by supplying you with all the information required to carry out production.

Furthermore, the information relevant to system operation is collected and arranged in order to make it available for a correct system monitoring.

JOB.CONSOLE includes the following modules:

Salvagnini Console

Main console for an intuitive management of the system which allows you to:

- easily save and find programs thanks to graphic tree structure
- use an editor for a simple correction of the programs
- semi-automatically move parts of the system, by means of a graphic interface, useful to easily use or access the system.

Salvagnini Console

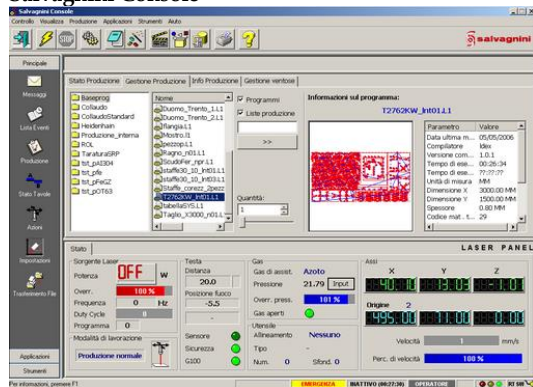

Salvagnini Editor

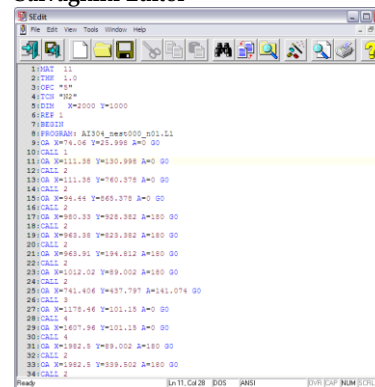

JOBLaser

Application used to dynamically schedule daily production; you can create a sequence of programs named "job" or list, on screen. JOBLaser allows you to queue and modify the sequence of jobs without waiting that the job being processed is finished. The production can be interrupted and then re-started from where it was interrupted. The programs that require a manual changeover of the head nozzle must be grouped in separate Jobs.

LDEX

By interacting with "Tool Shell" - technological parameters manager - the Salvagnini compiler compensates the cutting beam and optimizes path and dynamics increasing work quality and speed. LDEX can simultaneously compile groups of programs arranged in work directories.

Laser TRADJUST

With Laser TRADJUST the laser system is easier to use; even an inexperienced operator can effectively program the system thanks to the user-friendly interface.

The Laser TRADJUST dynamically interacts with the SiX control to automatically determine the cutting optimum values as a function of the movement direction, speed and instantaneous acceleration.

In this way

- The dynamic performance of the axes
 - the trajectories generated by the CAMLaser
 - the requirements of the cutting process
- are efficiently combined together.

Trajectory management

The head interpolated trajectories are calculated "off-line" to reduce any possible collisions which may be generated when rotating scrap along the cutting path. During

cutting, the system electromechanically recognizes any nozzle-workpiece collisions and carries out a few attempts to automatically restart the work-cycle in progress; if needed, it stops the cycle and warns you through an on screen message.

Restart management

The software directly manages, from the machine computer by means of selections from graphic interface, any interruptions of the program in progress and the re-starts from where it was interrupted or from any other piercing, position or part.

Tool Shell - cutting parameters database

This database collects and saves all of the cutting parameters and technological information of the Salvagnini standard materials. You can customize the database inserting or duplicating the parameters of a material.

Restart management

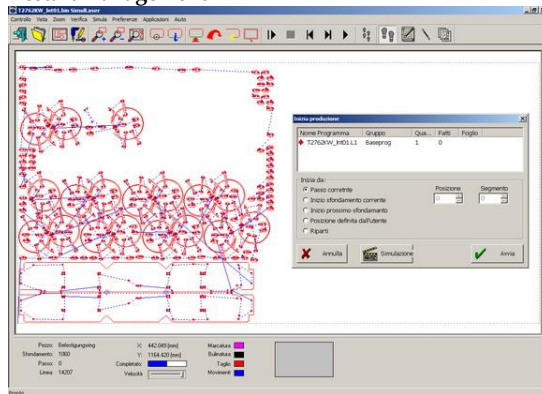

Local management of cutting parameters

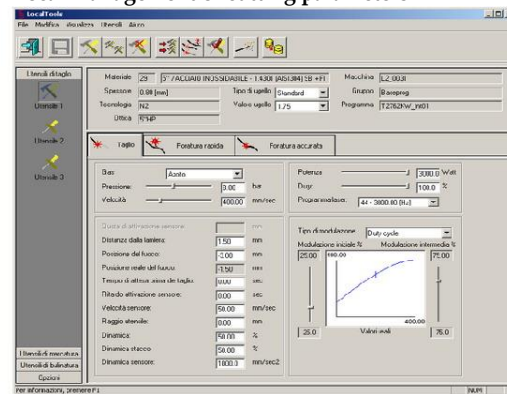

Local Tools - modification of cutting parameters from machine computer

This application allows you to modify from the machine computer and in a simple way, the cutting parameters of the program without re-elaboration in the office.

Maintenance Manager

Database of the analyses of the movements and cycles of the system components for an easy maintenance and wear checking of some parts; it includes a list of maintenance checks to be performed. You can add further checks or alarms to parts of the system.

EasyData

Diagnostic software integrated with the NC to interactively browse documentation using "web" technology (photos, hyperlinks, part code and automatic filters).

EasyData supplies information pertaining to each component managed by the Salvagnini NC. The system wiring or fluid-mechanical diagrams can be looked up directly on screen, automatically filtered on the component being diagnosed or by text searching the documentation.

EasyData

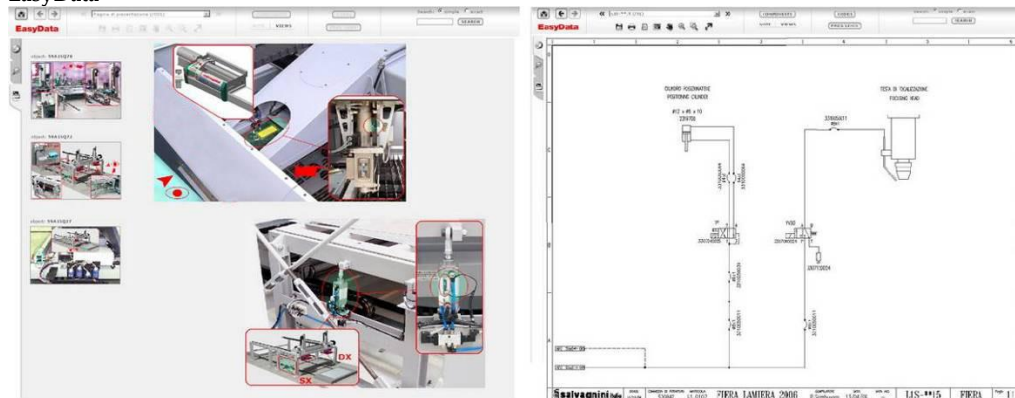

You can also:

- enrich the photo library with your own photos or notes
 - print one or more documental diagrams on paper or export them in PDF or JPG
- EasyData does not contain the documentation of any third party components integrated in the Salvagnini systems.

AUTOMATION

ADLL4020.SP - Connection for automatic loading/unloading

Connection of the laser machine which automatically loads plates from a suitably referenced pack and unloads processed plates.

The connection is composed of a main 2-bay self-supporting structure, which develops longitudinally, with a runway of raised parallel rails along which the frame composed of a loading carriage and an unloading "comb" (SP), moves.

The loading carriage is able to pick up single sheets from a pack, using a gripping device equipped with a set of suction cups.

This device can load both magnetic and non-magnetic material and checks for double sheets using a mechanical feeler pin.

The processed sheet is lifted by an unloading comb fixed to the structure of the gripping device (SP) and composed of a thick matrix of tubular elements (SP). The comb can insert itself between the table slats of the work surface to collect the cut metal sheets. A set of belts applied to the comb prevents the parts from scraping against it and improves the positioning accuracy onto the unloading table of cut parts.

The unloading operation of the processed sheet and the subsequent loading of the new sheet allow unmanned production and do not require the machining cycle to stop.

Its main operating characteristics are:

maximum sheet length	4064 mm
maximum sheet width	2032 mm
minimum sheet length	550 mm
minimum sheet width	500 mm
minimum sheet thickness (indication)	0.5 mm
maximum sheet thickness (mild steel)	15.0 mm
maximum sheet weight	1000 kg

ADLL4020.SP+PPC4020+TCE40205

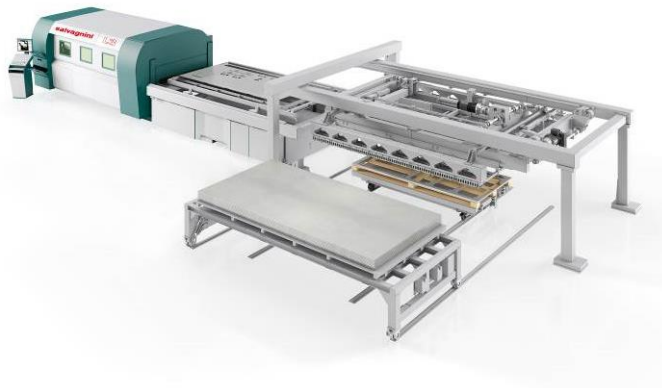

Extra bay for destacker - Lengthened main structure

An additional bay is added to the main structure of the indicated connection.

MCL40 - Cartesian manipulator

Cartesian manipulator able to pick up and stack parts processed by the laser system compatibly with the arrangement and reachability of the parts and of the gripping devices suction cups and with the pick-up force of the suction cups.

This connection is composed of:

- A 6000mm long structure fixed to the floor, with two parallel runways along which a carriage moves;
- two gripping devices with suction cups which slide along the carriage and which have a rotating motion around a vertical axis.

The gripping devices with suction cups can work separately and compatibly with dimensions of the parts, to stack the same parts according to the exiting direction from the laser system or rotated. If the dimensions of the part require it, the gripping devices can be used simultaneously to grip the part; in this case the part cannot be rotated during stacking.

The connection deposits and stacks parts in the range of action allowed by the structure fixed to the floor, usually on pallet.

MCL40 unloading connection



Part maximum weight with one gripping device (all suction cups activated)	65 kg
Part maximum weight with two gripping devices (all suction cups activated)	130 kg
Part minimum dimensions	200 x 100 mm
Part maximum thickness (indication)	6 mm

The possibility of unloading parts as a function of their size and shape must be subject to a feasibility study by Salvagnini.

The following software packages are always delivered with the Cartesian manipulator:

VisualStacker

This application automatically calculates where the parts will be gripped, the unloading cycle and the unloading positions of the processed parts; you can check and manually modify on screen the unloading solution set. Therefore you are relieved from the boring task of programming the unloading connection.

StateShell

This application displays the real situation of the unloading area and allows you to delete one or more stacks, if needed, after the finished products have been manually removed.

STORAGE

MTW4020.V5 - Five-position storing module

The MTW4020.V5 store allows up to 5 trays with packs of raw and/or processed material to be automatically stored close to the system.

Max. dimensions of the sheets	4064 x 2032 mm
Max. height of the pack (pallet+material)	230 mm
Maximum load per tray:	3000 kg

LTS4020 - Tray supporting station

This station feeds the laser system with the tray that the motorized table deposits on it. It is equipped with leafing magnets for the sheets to be processed.

Max. dimensions of sheet:	4064 x 2032 mm
---------------------------	----------------



CCT4020 - Carriage mobile on short side

Motorized carriage that handles pallets between the MTW store and the stacking connection. The carriage with the pack of processed material automatically moves along its short side from the stacking connections to the store for exchange with the TLV.MT table and vice-versa. The computer automatically manages all of the working cycles.

Characteristics:

- maximum capacity:	5000 kg
---------------------	---------

TLV4020.MT - Scissor table

Motorized scissor table that handles packs of sheet metal between the tray store and the destacking connection. The table with the pack of material automatically translates along its long side from the material loading area to the store and/or the feeding connection and vice-versa. Two chain-belts positioned on top of the table deposit/remove the tray from the storing levels. The computer automatically manages all of the table positioning cycles while the WMS software manages the packs of material in the store and coordinates the requests coming from the system.

Two electric motors ensure the horizontal movements of the table and of the chain-belts, while an autonomous power pack ensures the automatic adjusting of the height.

Max dimensions of sheets	4064 x 2032 mm
Max height of the pack (pallet+material)	230 mm
Carrying capacity	3000 kg
Vertical stroke	1550 mm



TCE40205 - Scissor table

Motorized scissor table able to automatically translate along its short side.

An electric motor ensures the horizontal motion of the table while an autonomous hydraulic power unit ensures the adjusting of the height.

The table requires a wooden pallet, min. height 140 mm, where to deposit processed metal sheets; the pallet is not included.

Max. dimension of the sheets	4064 x 2032 mm
Max height of the pack, including pallet	340 mm
Carrying capacity	5000 kg
Vertical stroke	550 mm

LOADING CONNECTION PERFORATED SHEET

PCD3015(SO) - Conveyor-destacker

Conveyor-destacker that permits the sheets to be picked up from one or two packs of sheet metal and to be fed in masked time, i.e. during the working cycle of the machine.

Special suction plates are mounted to pick up perforated sheets.

A device for checking double sheets verifies that the sheet raised is a single sheet; if not, various attempts to separate the sheets are made.

PCD3015

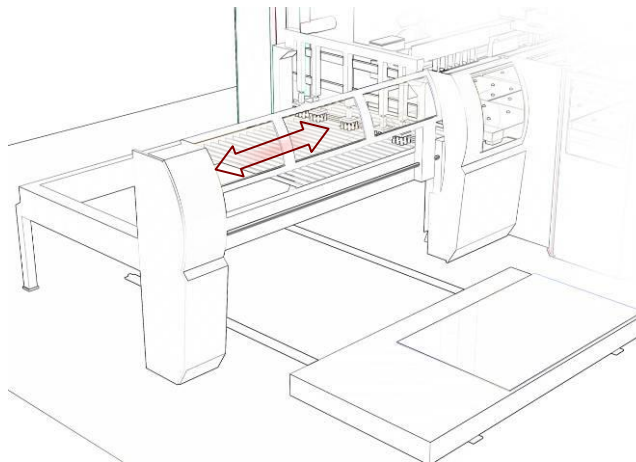

The PCD conveyor-destacker is able to feed sheets made of any material and with dimensions compatible with those of the machine to be fed.

Max dimension of sheet	3048 x 1524 mm
------------------------	----------------

Note: The limits and type of blanks to be handled are to be defined in close collaboration with the customer.

TC30155 - Scissor table

Motorized scissor table able to automatically translate along its own short side.

An autonomous hydraulic power unit ensures the horizontal motion of the table and the automatic adjusting of the height.

Max. dimension of the sheets	3048 x 1524 mm
Max height of the pack, including pallet	400 mm
Carrying capacity	5000 kg
Vertical stroke	550 mm

TRL5015 - Motorized roller-surface for operation in line

Surface with motorized rollers able to transfer metal sheets from a single sheet feeding device placed upstream to one or more S4 placed downstream of it.

Dimensions of the roller-surface ca. 5000 x 1500 mm

Extra bay for destacker - Lengthened main structure

An additional bay is added to the main structure of the indicated connection.

OFFICE SOFTWARE

OFFICE.L - Salvagnini software for office

Salvagnini software for managing system programs from the office. The application includes:

Office Console

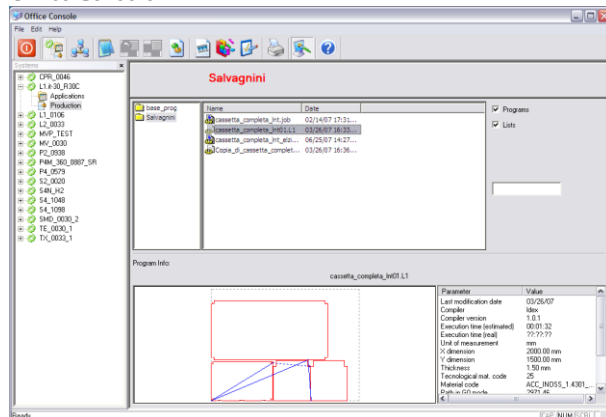

Salvagnini Editor

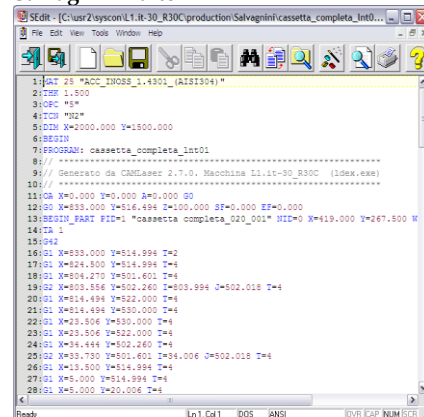

Office Shell

Graphic interface that allows fast access to the work structure of the programs and application to carry out:

- main manual programming and program editing actions
- organized saving of programs and of production lists for easy finding and to:
- access Salvagnini programming applications (if available)
- transfer programs from and to systems present in the production area.

LDEX

Salvagnini compiler-elaborator of laser cutting programs; it provides information regarding program integrity and suggestions on wrong info typed in by the operator.

OFFICE.L add. license - Salvagnini software for office, additional user license